

User Manual





Three Phase Multifunctional Energy Meter – ZTC55L

SAFETY INFORMATION

Please read this chapter carefully and examine the equipment carefully for potential damages which might arise during transport and to become familiar with it before continue to install, energize and work with TC55M-L series.

This chapter deals with important information and warnings that should be considered for safe installation and handling with a device in order to assure its correct use and continuous operation.

If equipment is used in a manner not specified by the manufacturer, the protection provided by the equipment may be impaired.

WARNING		A hazardous situation which, if not avoided, could result in serious injury.
CAUTION		A hazardous situation which, if not avoided, could result in minor or moderate injury.
NOTICE		Practices not related to physical injury.

Please note: This booklet contains instructions for installation and use of TC55M-L series.

Installation and use of a device also includes handling with dangerous currents and voltages therefore should be installed, operated, serviced and maintained by qualified personnel only.

Rayfull Electric is responsible for coordinating therating and the characteristics of the supply side overcurrent protection devices with the maximum current rating and, in the case of direct connectedmeters, with the UC rating of the metering equipment.

Before installing the TC55M-L series, please check the following points carefully:

- It's recommended to power off all connected external devices;
- The connecting wire, which connects the device to the external circuit, should be of an appropriate size in accordance with local regulations regarding the maximum allowable current breaker or other overcurrent protection devices used in the circuit;
- An external switch or circuit-breaker should be installed on the power supply wires, which will be used to disconnect the meter and the device supplying energy. It is recommended that this switch or circuit-breaker is placed near the meter because that is more convenient for the operator. The switch or circuit-breaker must comply with the specifications of the building's electrical design and all local regulations;

- An external fuse or thermal cut-off used as an overcurrent protection device for the meter must be installed on the supply side wires;
- It is recommended that this protection device is also placed near the meter for the convenience of the operator. The overcurrent protection device must comply with the specifications of the building's electrical design and all local regulations;
- The device can be installed on a TH35-7.5 DIN rail;
- This meter can be installed indoors or outdoors, enclosed in a meter box which is sufficiently protected, in accordance with local codes and regulations;
- To prevent tampering, an enclosure with a lock or a similar device can be used;
- The meter must be installed against a fire resistant wall;
- The meter must be installed in a well-ventilated and dry place;
- The meter must be installed in a protective box if the meter is exposed to dust or other contaminants;
- The meter can be installed and used after being tested and can be sealed afterwards;
- The meter should be installed in a location where the meter can be read easily;
- In case the meter is installed in an area with frequent surges, for example due to thunderstorms, welding machines, inverters, etc., the meter requires Surge Protection Device protection;
- The device should be sealed immediately after installing it in order to prevent tampering.

Índice

SAFETY INFORMATION	2
Chapter 1. Product Introduction	5
1.1 Brief Introduction	5
1.2 Product Characteristics	5
1.3 Applications	5
Chapter 2. Technical Specifications	6
2.1 Specifications	6
2.1.1 Electrical Specifications	6
2.1.2 Mechanical Specifications	7
2.1.3 Environment Specifications	7
2.1.4 Electromagnetic Compatibility	7
2.1.5 Safety Specifications	8
2.1.6 Communication Specifications	8
2.2 Size	8
2.3 Wiring Diagram	9
2.3.1 PT Wiring	11
2.3.2 Terminals and Connection Cable	11
Chapter 3. Operation	12
3.1 Button Definition	12
3.2 Displays	12
3.2.1 Full View of Display	12
3.3 Settings	17
3.3.1 Password	17
3.3.2 Communication Settings	18
3.3.3 CT Settings	19
3.3.4 PT Settings	19
3.3.5 System Settings	19
3.3.6 Pulse Settings	21
3.3.7 Demand Settings	22
3.3.8 Time Settings	22
3.3.9 LoRaWAN Communication Settings	23

Chapter 1. Product Introduction

1.1 Brief Introduction

TC55M-L series are three phase external CT connected multifunctional energy meter to measure and analyze the most important electrical parameters, including voltage, current, four-quadrant power parameters, power factor, total harmonic, and etc. And it can also read a variety of energy parameters, involving bidirectional active and reactive energy, four-quadrant energy, and so on. The series realizes the measurement and analysis of power parameters in various power grid environments, such as 1P2W, 3P3W and 3P4W.

The TC55M-L series have both LoRaWAN and RS485 communication interface with highest baudrate 38400bps, supporting Modbus or DLT645 protocol for remote reading.

At the same time, the large-screen LCD and touch buttons help users to view and set various measurement parameters on site.

Password protection function is added to greatly improve the data security.

1.2 Product Characteristics

- Multifunctional Parameters: V, A, W, Var, VA, kWh, kVarh, PF, PA, ...;
- THD: Voltage THD and Current THD;
- Bidirectional Energy Measurement: Import/Export Active Energy, Import/Export Reactive Energy;
- Direct Voltage Input or High Voltage(PT) Input;
- Current Transformer Input: 1A/5A, or mV/mA CT input, or Rogowski coils (RC) input;
- CT Reverse-Connect Correction Function;
- Pulse output, RS485 communication with highest baudrate 38400bps;
- LoRaWAN Wireless Communication;
- Available Protocol: Modbus RTU, DL/T645-2007;
- Touch-Button: Improve the performance of buttons and reduce the operation error;
- Large-screen LCD display with configurable white backlit interval;
- LCD refresh time: 1 second, supporting manually or automatically scroll display (configurable).

1.3 Applications

TC55M-L series are designed for solar PV, EV charging, wind power generation and other electrical systems, which are also widely used in power monitoring systems, future community, SCADA systems and other energy management systems.

Chapter 2. Technical Specifications

2.1 Specifications

2.1.1 Electrical Specifications

Accuracy	Voltage/Current	Class 0.5, Refer to IEC 61557-12
	Active Power	Class 0.5, Refer to IEC 61557-12
	Reactive Power	Class 2, Refer to IEC 61557-12
	Apparent Power	Class 1, Refer to IEC 61557-12
	Active Energy	Class 0.5S, Refer to IEC 62053-21/22, IEC 61557-12
	Reactive Energy	Class 2, Refer to IEC 62053-23; Class 2, Refer to IEC 61557-12
	Power Factor	Class 1, Refer to IEC 61557-12
	Frequency	Class 0.2, Refer to IEC 61557-12
Data Upgrading Rate		1s (Optional: 100ms)
Voltage Input	Rated Voltage	3x230VAC(L-N)/400VAC(L-L)
	Voltage Input	Measurement range: 30 ~ 300 VAC(L-N); 30 ~ 500 VAC(L-L)
	PT Input	Max. Input:500000 VAC
	Loop Impedance	1M Ω
	Frequency	45 ~ 65 Hz
	Overload Capacity	2x Rated Voltage by lasting 1s
Current Input	CT2	Rated value: 1A/5A(Default), 100mA/mV(Optional)
	CT1	1 ~ 9999 A
	Measurement range	0.003 ~ 6 A, Rated: 5A
	Loop Impedance	<0.01 ohm
	Overload Capacity	20x Max. Current by lasting 0.5s
Aux.Power Supply	Voltage Range	80 ~ 300 VAC / 100 ~ 420 VDC
	Frequency Range	45 ~ 65 Hz
	Power Consumption	< 4VA/0.5W
Pulse Output	Pulse Type	Open collector optocoupler
	Pulse Constant	Configuration: 0.001, 0.01, 0.1, 1, 10, 100 kWh/kvarh

	Pulse Width	Configuration: 60, 100(Default), 200ms
	Pulse Output Type	Configuration: Import/Export/Total active/Total Reactive kWh
	Class	Class A, Refer to IEC 62053-31
	Voltage Input	5 ~ 27 VDC
Pulse Light		Pulse constant:5000imp/kWh (Energy of Secondary Side)
Power Consumption Class	Self-Consumption per phase	Voltage Circuit: <2W/10VA; Current Circuit: <1VA

2.1.2 Mechanical Specifications

IP Class	LCD display: IP51(Indoor); Whole meter: IP30
Installation	TH35-7.5 DIN Rail
Flammability Class	UL 94 V-0
Utilization Category	UC2

2.1.3 Environment Specifications

Operation Temperature	-25 ~ +55°C
Storage Temperature	-40 ~ +80°C
Humidity	<90%, no condensing
Pollution Degree	2
Altitude	<2000m
Vibration Frequency	Range: 10~150Hz, Refer to IEC 60068-2-6

2.1.4 Electromagnetic Compatibility

Electrostatic Discharge	Refer to IEC 61000-4-2 ⁽¹⁾ , Level 4
Immunity to Radiated Fields	Refer to IEC 61000-4-3 ⁽¹⁾ , Level 3
Immunity to Electrical Fast Transients	Refer to IEC 61000-4-4 ⁽¹⁾ , Level 4
Immunity to Surges	Refer to IEC 61000-4-5 ⁽¹⁾ , Level 4
Immunity to Conducted Disturbances	Refer to IEC 61000-4-6 ⁽¹⁾ , Level 3
Immunity to Magnetic Fields	Refer to IEC 61000-4-8 ⁽¹⁾
Immunity to Voltage Dips	Refer to IEC 61000-4-11 ⁽¹⁾
Radiated Emissions	EN55011, Class B
Conducted Emissions	EN55011, Class B
Harmonics Emissions	Refer to IEC61000-3-2 ⁽¹⁾

(1): The experimental test is carried out according to the grade requirements of industrial grade products in IEC61326-1.

2.1.5 Safety Specifications

Installation Degree	CAT III, Refer to IEC 61010-1
Over-Voltage Degree	CAT III, Refer to IEC 61010-1
Insulation	AC Withstand Voltage: 4kVAC by lasting 1min
	Pulse Withstand Voltage: 6kVAC - 1.2/50μS waveform
Insulation Degree	Double Insulation, Refer to IEC 61010-1

2.1.6 Communication Specifications

Interface and Protocol	2-Wire RS485; Modbus RTU(Default), DL/T645-2007(Optional)
Baudrate	1200, 2400, 4800, 9600(Default), 19200, 38400 bps
Parity	None(Default), Even, Odd
Stop Bit	1(Default), 2
Response Time	<100ms
Bus Type	Semi-duplex
Distance	Max. 1000m
Bus Load	Max. 64pcs
Wireless	
LoRaWAN	LoRaWAN V1.0.4.Class C

2.2 Size

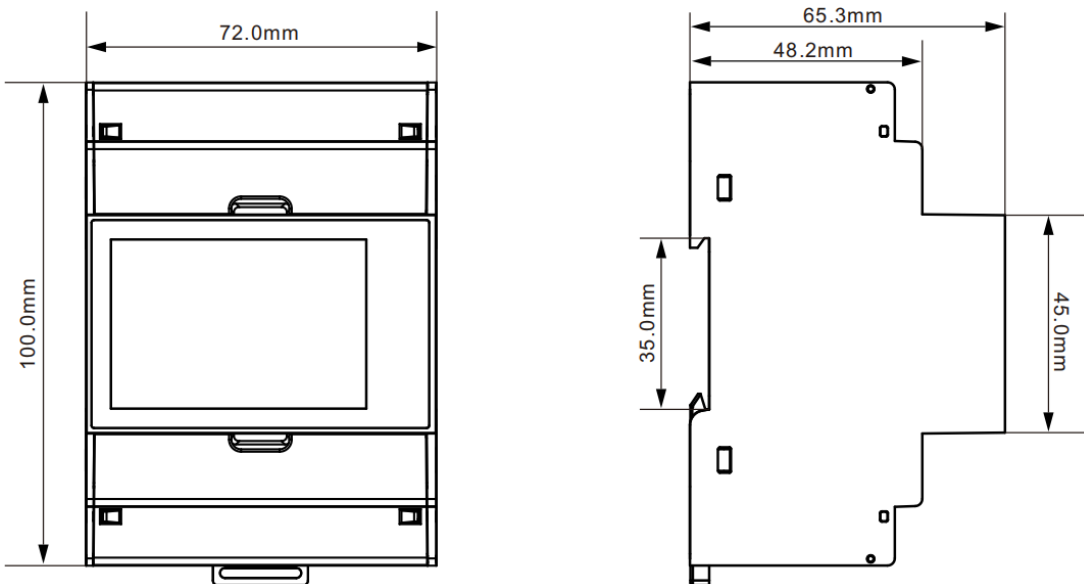

2.3 Wiring Diagram

❖ Three Phase 4 Wires

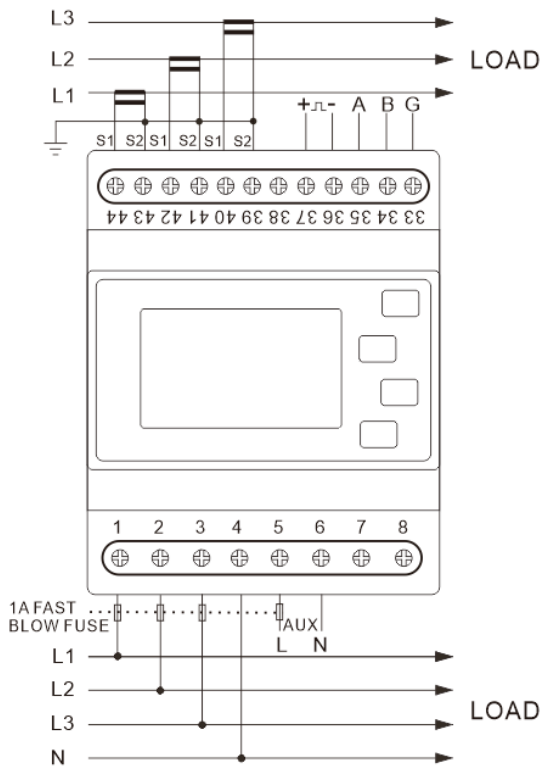

❖ Three Phase 3 Wires

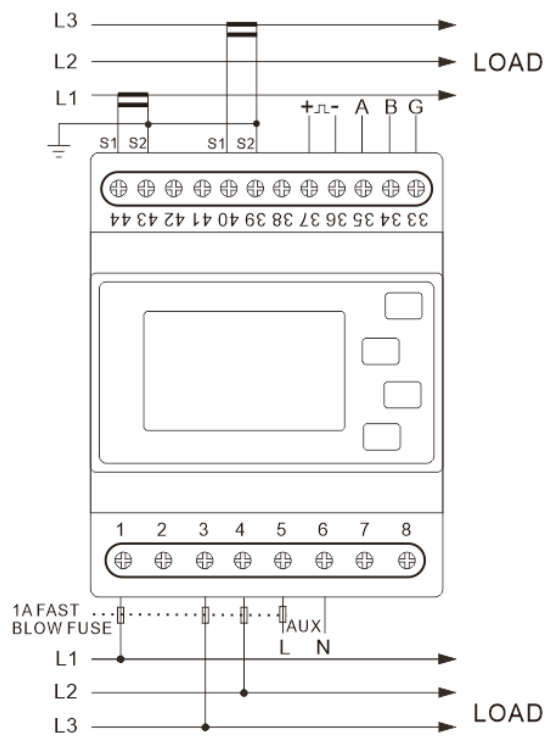

❖ Two Phase 3 Wires

❖ Single Phase 2 Wires (L+N, 1CT)

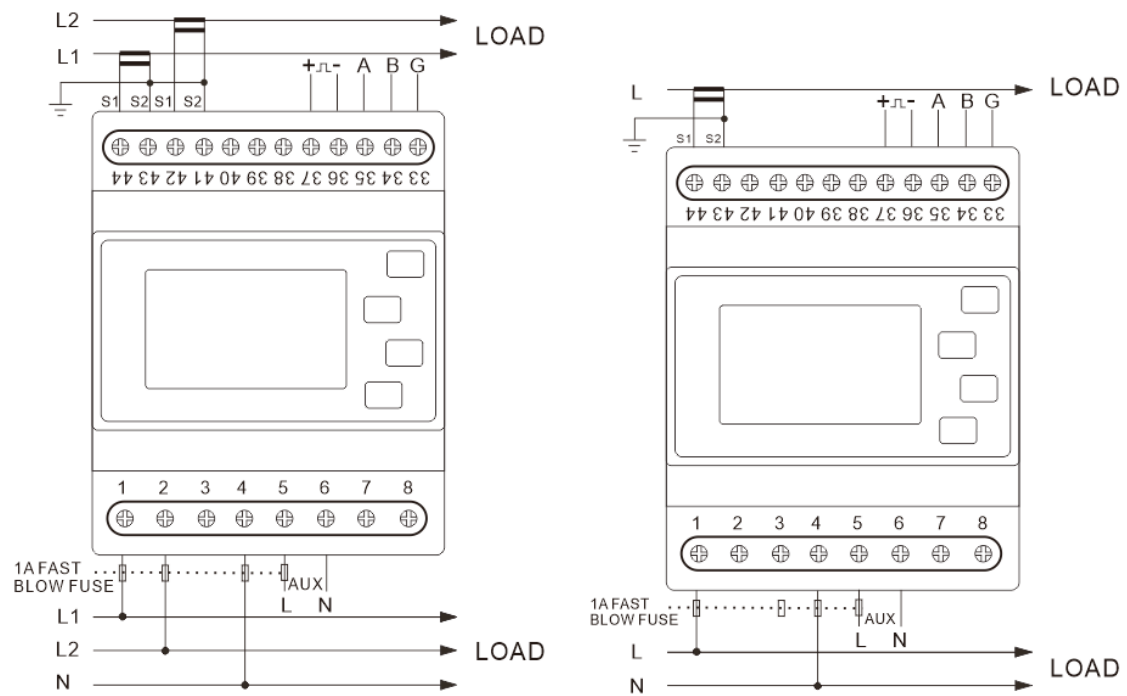

❖ **Single Phase 2 Wires (L+N, 3CT)**

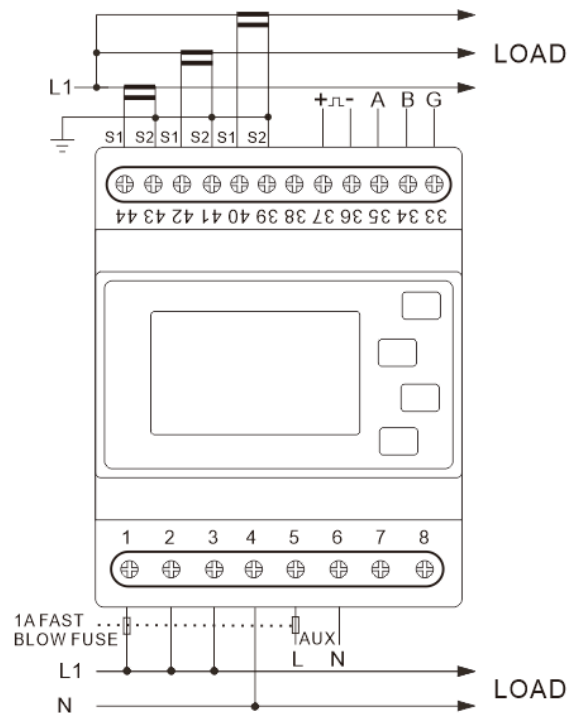

2.3.1 PT Wiring

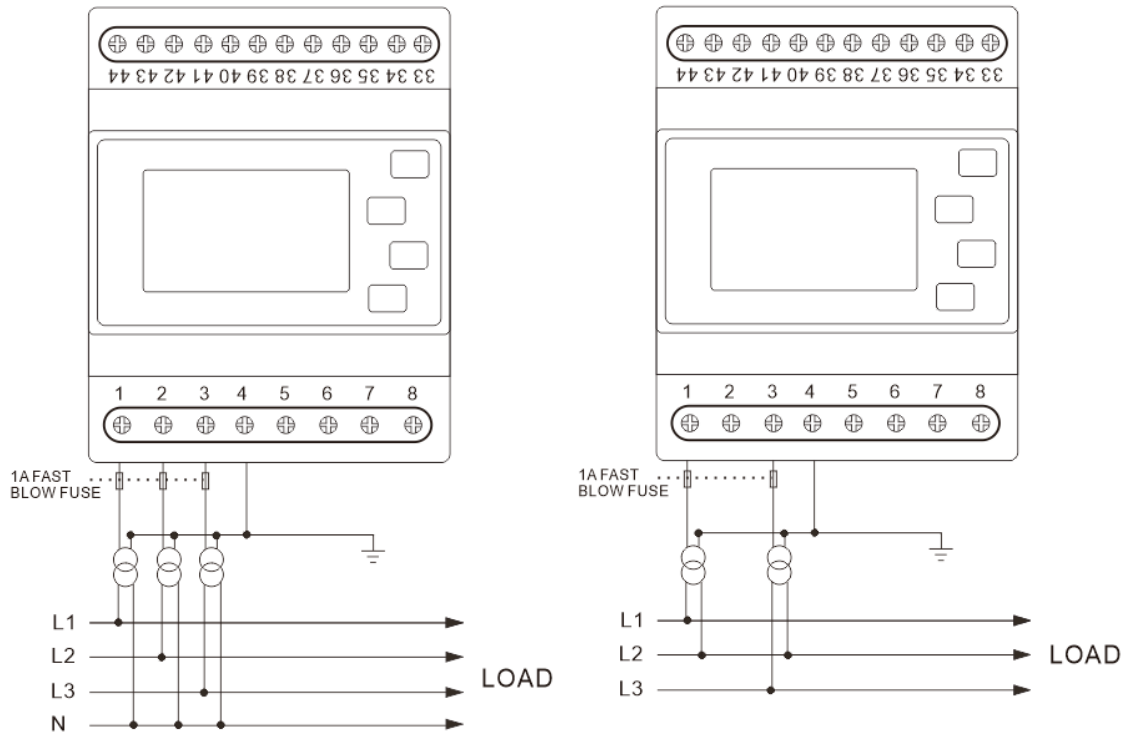





2.3.2 Terminals and Connection Cable

Voltage Input Terminals	Wire Diameter: 26 ~ 12 AWG Torque: 0.5 N.m (Max.)
Current Input Terminals	Wire Diameter: 26 ~ 12 AWG Torque: 0.5 N.m (Max.)
Aux.Power Supply Terminals	Wire Diameter: 26 ~ 12 AWG Torque: 0.5 N.m (Max.)
COMM/Pulse/DS Terminals	Wire Diameter: 26 ~ 12 AWG Torque: 0.5 N.m (Max.)
Temperature Rating of Connection Cable	23°C±2°C

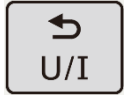
Chapter 3. Operation

3.1 Button Definition

Button	Short-Press	Long-Press
	1, On main display: to check voltage, current, and so on; 2, On setting display or Aux. Display: to exit or return	On main display: to enter the aux. displays.
	1, On main display: to check power factor, Max. Demand, and so on; 2, On setting display or Aux. Display: to page up or add value.	None
	1, On main display: to check power; 2, On setting display or Aux. Display: to page down or reduce value.	None
	1, On main display: to check energy and time; 2, On setting display: to move right.	1, On main display: to enter setting mode; 2, On setting display: to enter setting mode or to confirm.



Note: Long-press means the button is pressed longer than 3s, otherwise it's a short-press.

3.2 Displays

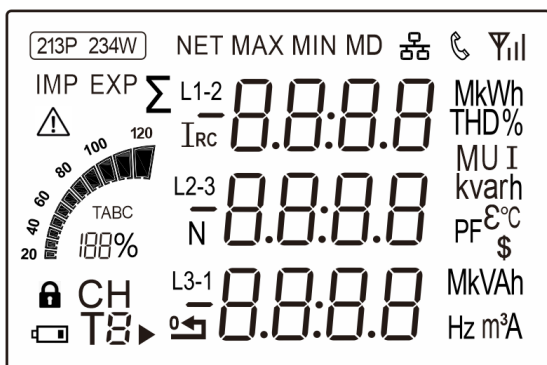
3.2.1 Full View of Display



 After a short-press, the following displays will be showed.			
L1 230.0 L2 230.0 L3 230.0 V	Phase-to-Neutral Voltage Note: not available under 3P3W	L1-2 400.0 L2-3 400.0 L3-1 400.0 V	Phase-to-Phase Voltage

L1 5.000 L2 5.000 L3 5.000 A	Current	L1 03.06 THD% L2 02.78 U L3 04.35	Phase-to-neutral Voltage THD
L1-2 02.74 THD% L2-3 03.80 U L3-1 00.00	Phase-to-Phase Voltage THD Note: only available	L1 03.56 THD% L2 02.45 I L3 01.87	Current THD
 After a short-press, the following displays will be showed.			
Σ 0.500 PF 50.00 Hz	Total Power Factor and Frequency	L1 0.500 L2 0.500 PF L3 0.500	Power Factor of Each Phase
MD L1 5.000 L2 5.000 L3 5.000 A	Max. current Demand of Each Phase	Σ MD 3.680 kW 5.702 kvar 3.598 kVA	Max. Demand of Total Active Power/Reactive Power/Apparent Power
 After a short-press, the following displays will be showed.			
L1 0.575 kW L2 0.575 L3 0.575	Active Power of Each Phase	L1 0.996 L2 0.996 kvar L3 0.996	Reactive Power of Each Phase
L1 1.150 L2 1.150 L3 1.150 kVA	Apparent Power of Each Phase	Σ 1.725 kW 2.988 kvar 3.450 kVA	Total Active Power/Reactive Power/Apparent Power
 After a short-press, the following displays will be showed.			
Σ 0000 kWh 30.10	Total kWh	IMP 0000 kWh 15.05	Import kWh
EXP 0000 kWh 15.05	Export kWh	Σ 0023 63.49 kvarh	Total kVarh

IMP 0023 00.26 kvarh	Import kVarh	EXP 0000 63.23 kvarh	Export kVarh
----------------------------	--------------	----------------------------	--------------





■ Display of kWh

For TC55M-L series, the significant digit is displayed according to the value of energy.

The rule is as below:

0.00 kWh/kVarh → 999999.99 kWh/kVarh → 1000000.0 kWh/kVarh → 9999999.9 kWh/kVarh → 10000000 kWh/kVarh → 99999999 kWh/kVarh → 0.00 kWh/kVarh

3.2.2 Auxiliary Displays

When it's on the main display, long press  to enter the interfaces of auxiliary displays. Short press  and  to scroll. Short press  to return to main display.

If there is no button operation longer than 1min, the meter will go back to main display automatically.

➤ LoRaWAN Information:

1. Status of LoRaWAN to Join OTAA

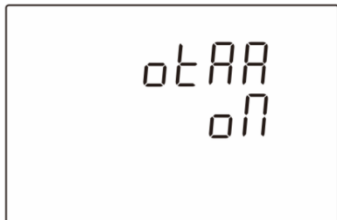

Instruction: Long press  to join OTAA.

Note: the 2nd and 3rd line indicate the current status.

: Join LoRaWAN network successfully;

: in the process of joining LoRaWAN network;

: The joining operation is queued up to the network.

The 3rd line also indicates the time left to wait. Unit: s

The left figure shows there are 230s left for the meter to join the network

Note: After the meter is powered on, a waiting time of 5-600 seconds will be randomly generated to prevent a large number of products from being

2. DEVEUI Information



Instruction: Long press  to next menu.

Short press  and  to scroll.

Short press  to return.



The DEVEUI consists of 8 bytes in Hex(P1-P2).



3. APPEUI Information



Instruction: Long press to next menu.

Short press and to scroll.

Short press to return.

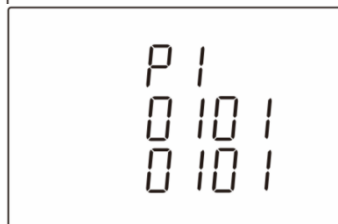

The APPEUI consists of 8 bytes in Hex(P1-P2).

The left figure shows the APPEUI of current meter is 01 01 01 01 01 01 01 01

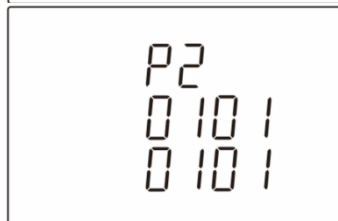

4. APPKEY Information



Instruction: Long press to next menu.

Short press and to scroll.

Short press to return.

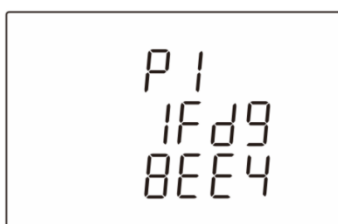

The APPEUI consists of 16 bytes in Hex(P1-P4).

The left figure shows the APPKEY of current meter is 1F D9 8E E4 D4 EA CE

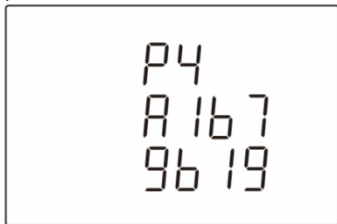
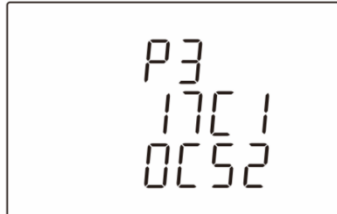

5. Status of ADR



ON: ADR is open;
OFF: ADR is off.

Note: ADR function refers to the function that the devices and gateways in

6. Offline Detection Time

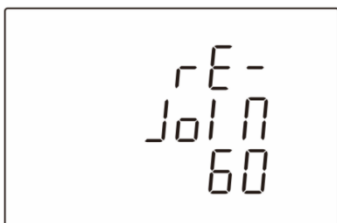

Unit: Min.

The left figure shows the current offline detection time is 60mins.

Note: This function is used to detect whether the meter is offline. If it is judged to be offline, the meter automatically re-joins the network.

The rules for determining offline are as follows: If the meter does not receive any data from the gateway within the set time range, it is judged offline.

7. RX2 Rate of LoRaWAN Network

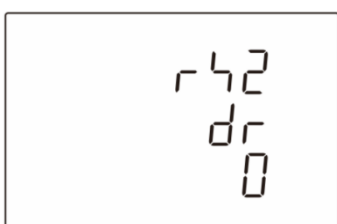

The left figure shows the RX2 rate of current meter is DR0.

8. RX2 Frequency Band of LoRaWAN Network



The left figure shows the frequency band of RX2 is 869.5MHz.

9. Test of Upload



Instruction: Long press  to send a request from meter to gateway.

Note: the 3rd line indicates the current status of operation.

Non: No request is ready to be sent (null);

YRI T: Requesting now and wait for result;

oH: Request is successfully sent;

FAI L: Request is failed.

➤ Meter Information:

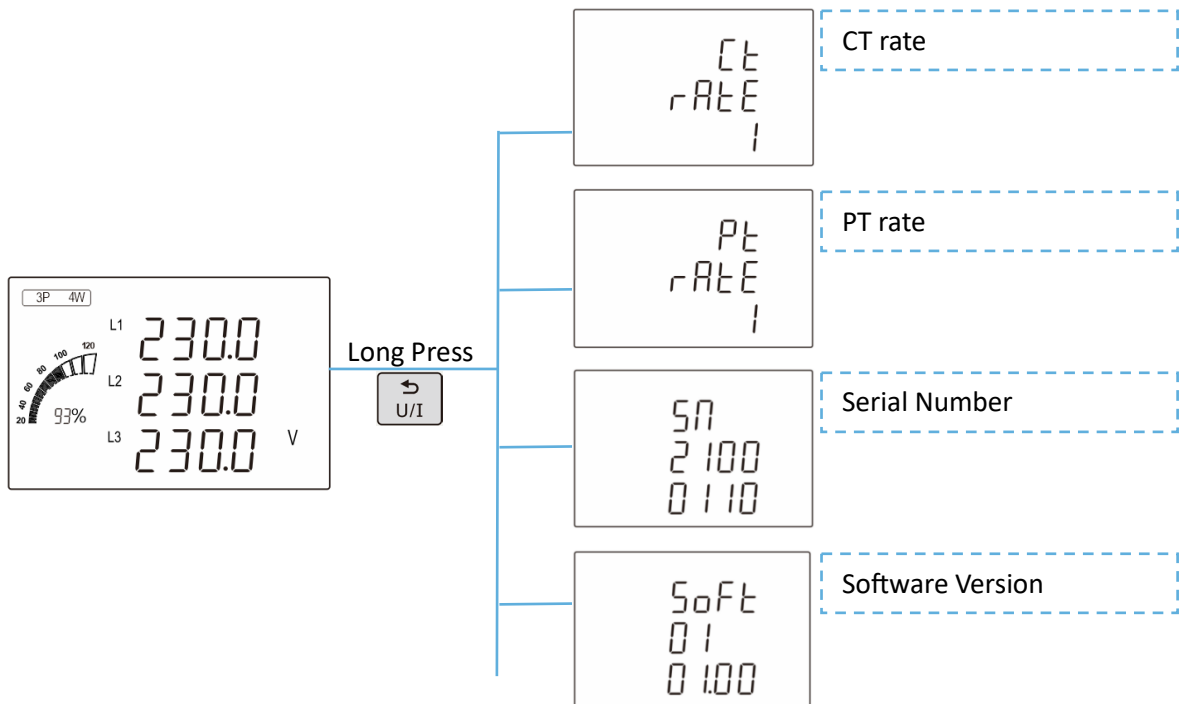



3.3 Settings

3.3.1 Password

On the main display, long press  to input the password. (Default: 1000)



Short press  and  to choose the number and short press  to move.



After inputting a password, long press  to confirm. If the password is correct, the meter will enter setting mode.



Under the password input display, short press  to go back to main display. Also, if there is no button operation longer than 1min, the meter will go back to main display automatically.



3.3.2 Communication Settings

Communication settings include Modbus address, baud rate, parity, stop bit.

Instruction: Long press  to enter the setting mode.

Short press  and  to choose. Long press  to enter the exact menu.

Short press  and  to choose the value. Short press  to move.

Long press  to confirm and short press  to return.

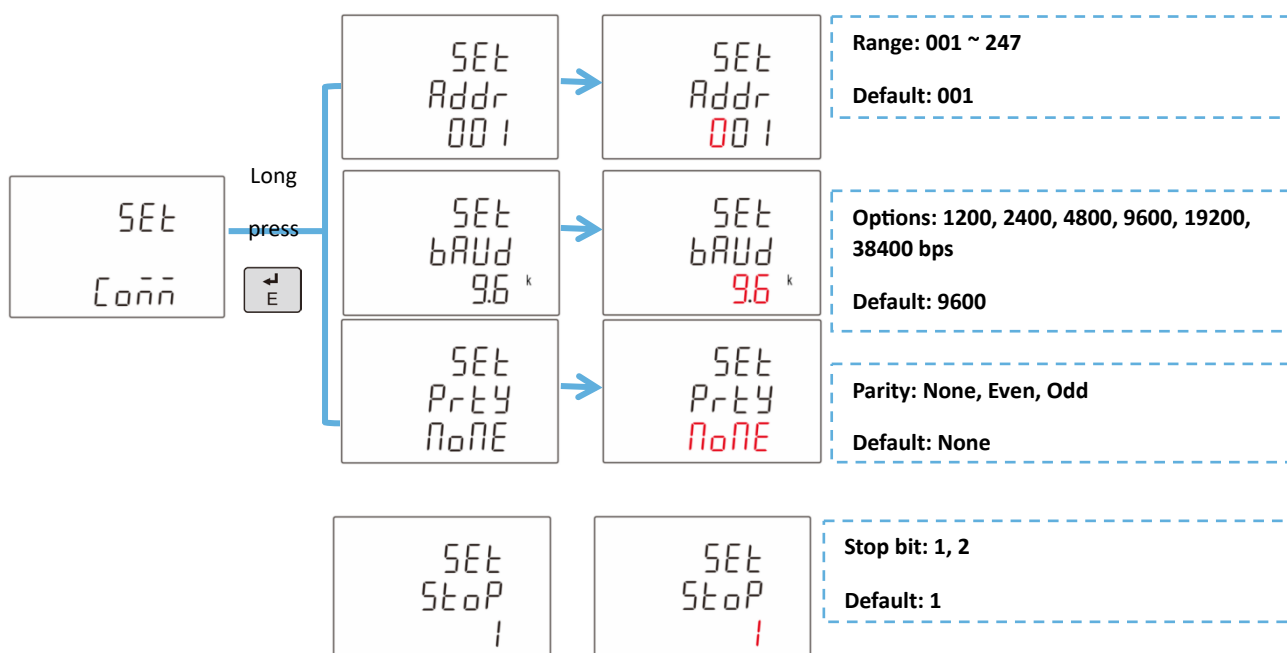

3.3.3 CT Settings

CT settings include CT1 value and CT2 value.

Instruction: Long press to enter the setting mode.

Short press and to choose. Long press to enter the exact menu.

Short press and to choose the value. Short press to move.

Long press to confirm and short press to return.

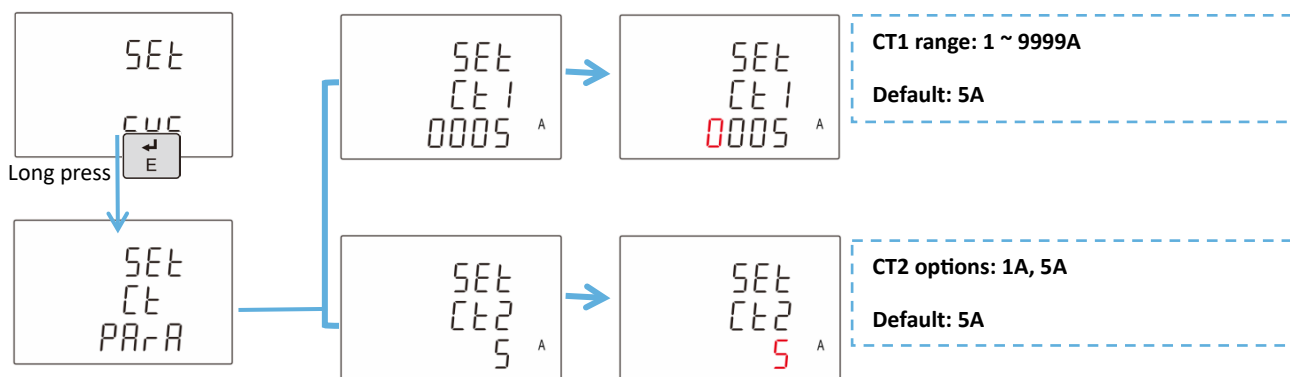

3.3.4 PT Settings

PT settings include PT1 value and PT2 value.

Instruction: Long press to enter the setting mode.



Short press and to choose. Long press to enter the exact menu.

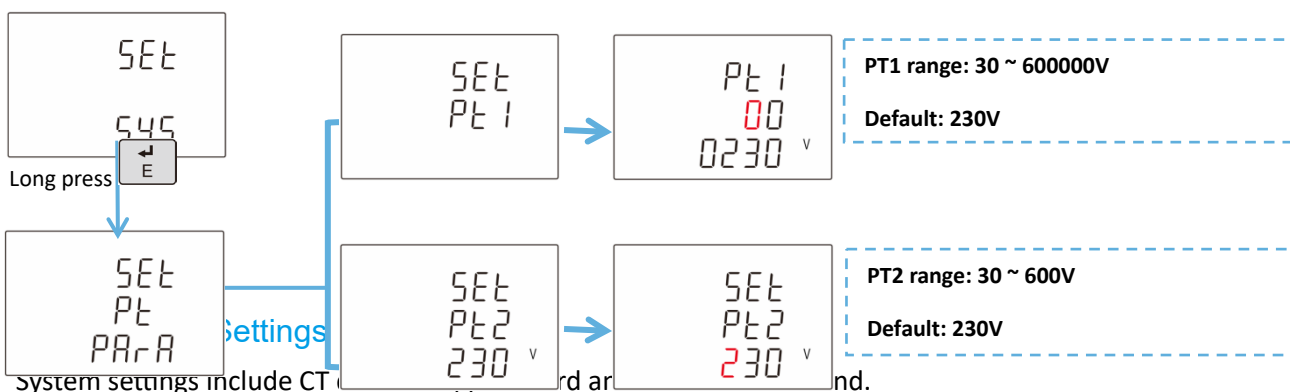

Short press and to choose the value. Short press to move.



Long press to confirm and short press to return.



Instruction: Long press  to enter the setting mode.

Short press  and  to choose. Long press  to enter the exact menu.

Short press  and  to choose the value. Short press  to move.

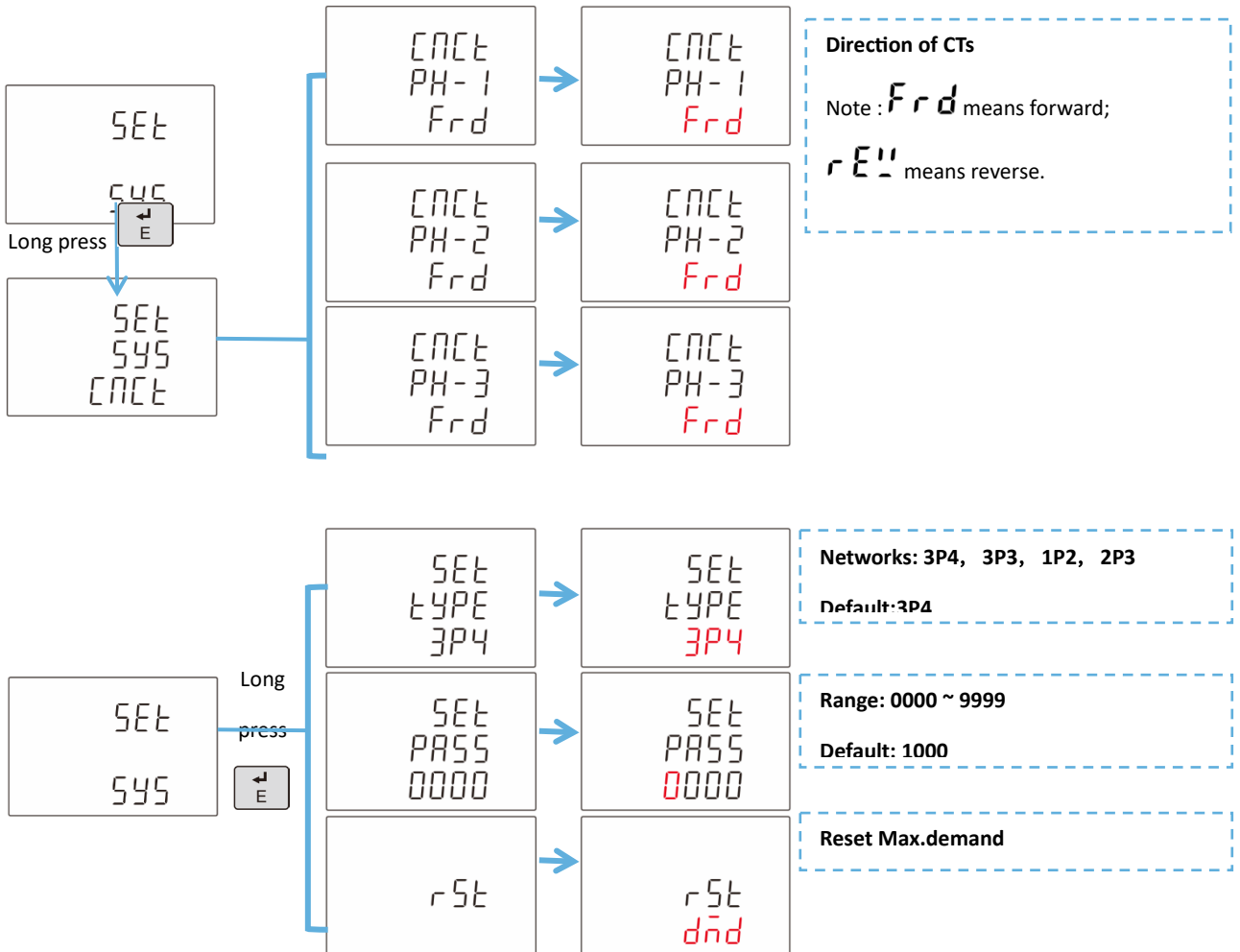

Long press  to confirm and short press  to return.







3.3.6 Pulse Settings

Pulse settings include pulse constant, pulse width, pulse output type.

Instruction: Long press  to enter the setting mode.

Short press  and  to choose. Long press  to enter the exact menu.

Short press  and  to choose the value. Short press  to move.

Long press  to confirm and short press  to return.

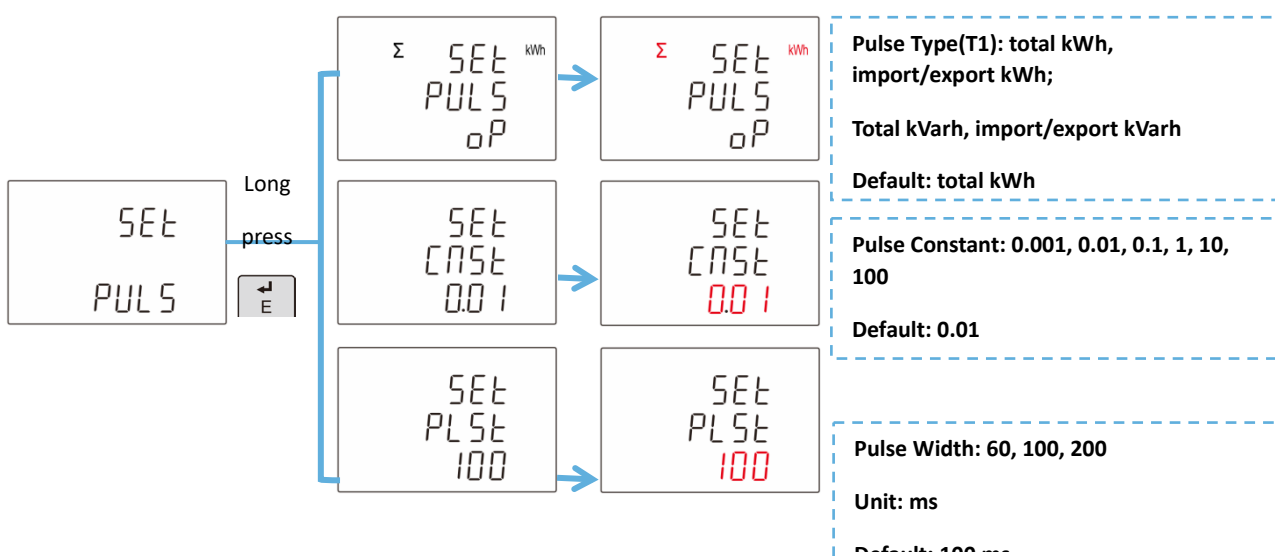





Table 1 : Pulse Output Type



Character on Display	Pulse Output Type	Character on Display	Pulse Output Type	Character on Display	Pulse Output Type
Σ kWh	Total kWh	IMP kWh	Import kWh	EXP kWh	Export kWh
Σ kvarh	Total kVarh	IMP kvarh	Import kVarh	EXP kvarh	Export kVarh



3.3.7 Demand Settings

Demand settings include demand period, slide time.

Instruction: Long press  to enter the setting mode.

Short press  and  to choose. Long press  to enter the exact menu.

Short press  and  to choose the value. Short press  to move.

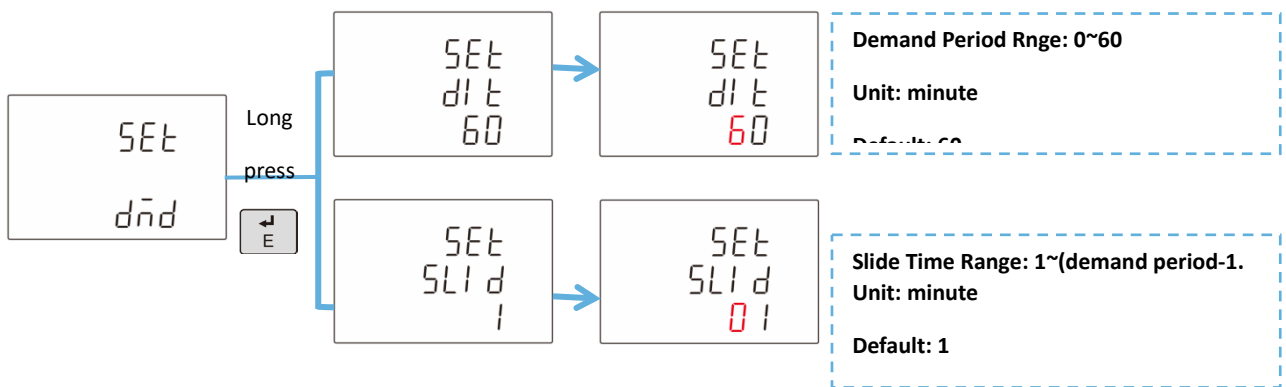

Long press  to confirm and short press  to return.







3.3.8 Time Settings

Time settings include backlit time, scroll time.

Instruction: Long press  to enter the setting mode.

Short press  and  to choose. Long press  to enter the exact menu.

Short press  and  to choose the value. Short press  to move.

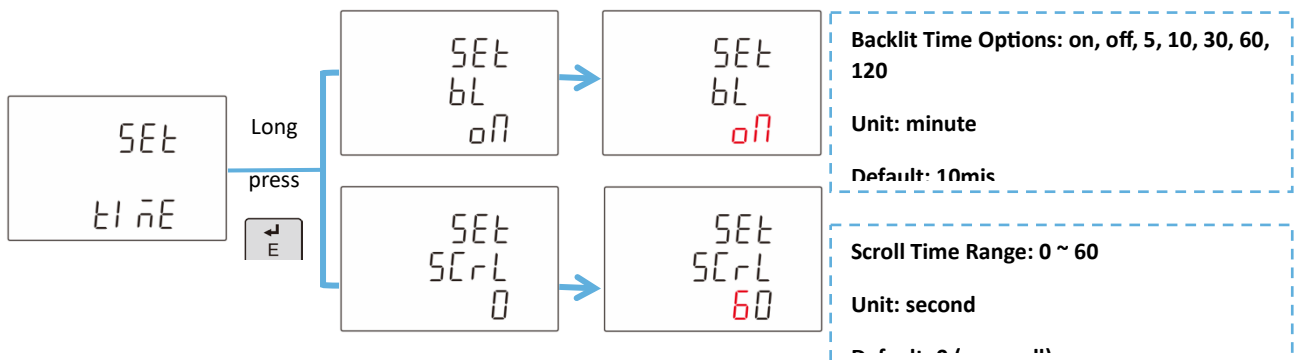

Long press  to confirm and short press  to return.







3.3.9 LoRaWAN Communication Settings

LORAWAN Communication settings include offline detection time, ADR function, LoRaWAN information, restart LoRaWAN module.

Instruction: Long press  to enter the setting mode.

Short press  and  to choose. Long press  to enter the exact menu.

Short press  and  to choose the value. Short press  to move.

Long press  to confirm and short press  to return.

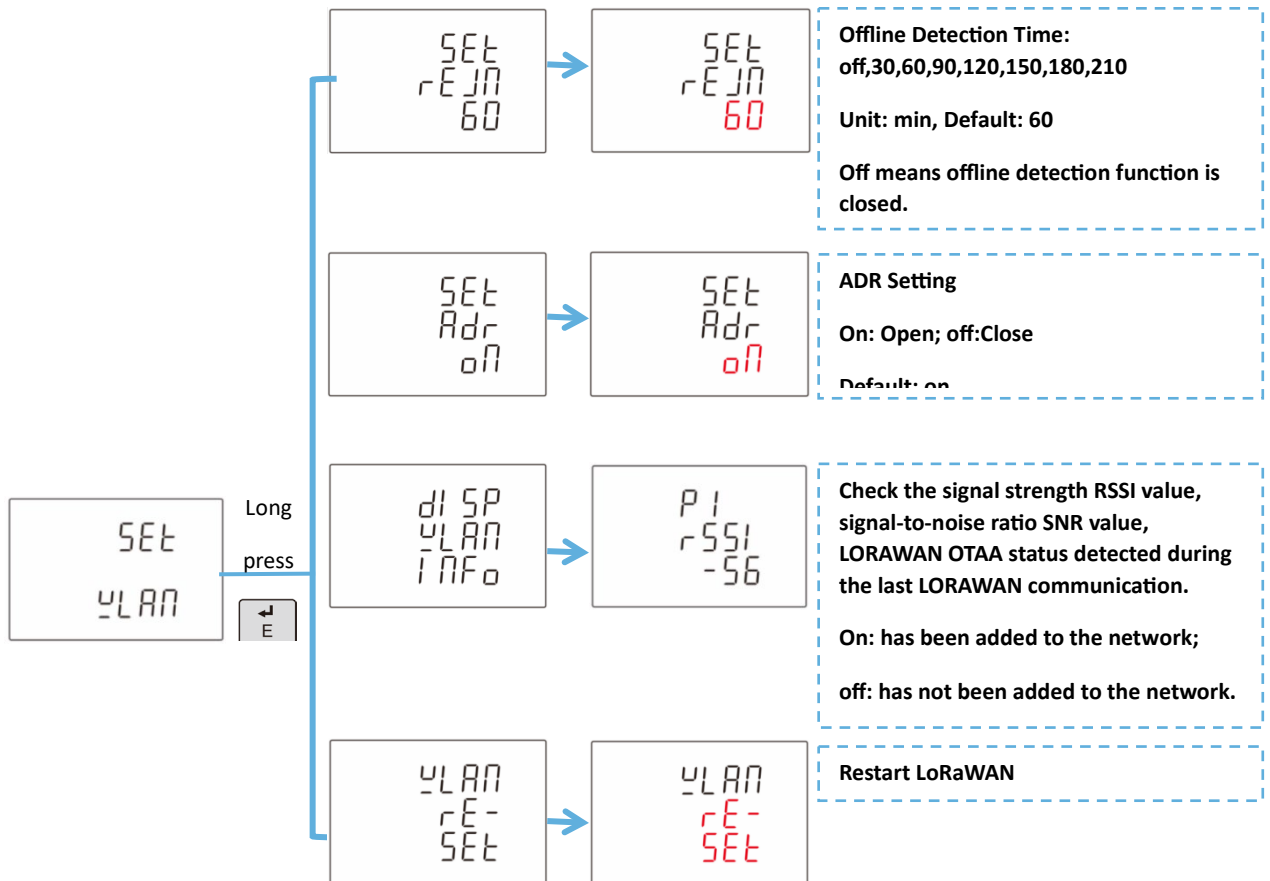



**Your universe just a click
away.**

[.website](#) 